



Model Number

LS610-DA-IBS/F2
Optical data coupler

Features

- Devices for INTERBUS
- Plug connection for fast mounting
- No parameterization
- Usable up to detection range 0
- Line indicator for signal strength

Dimensions

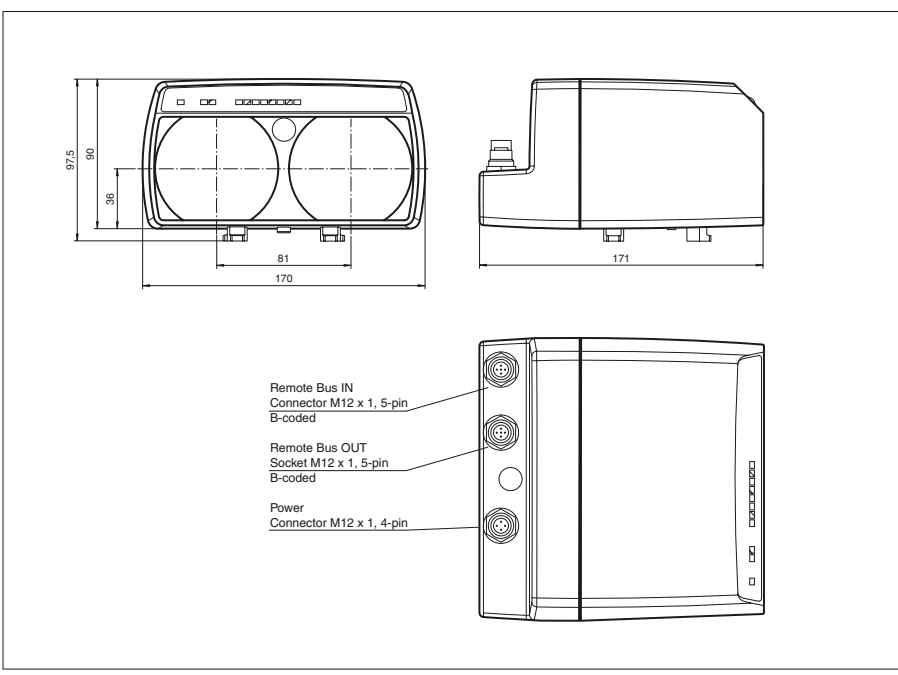

Electrical connection

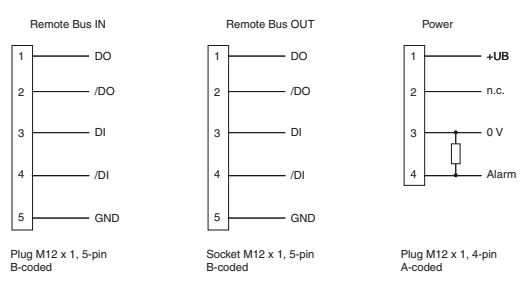

Release date: 2013-08-21 10:34 Date of issue: 2013-08-21 131635_eng.xml

Refer to "General Notes Relating to Pepperl+Fuchs Product Information".

Technical data**General specifications**

Effective detection range	0 ... 120 m
Threshold detection range	140 m
Light type	modulated infrared light
Approvals	CE, cULus
Diameter of the light spot	2 m at a distance of 100 m
Angle of divergence	1.1 °
Ambient light limit	> 10000 Lux

Functional safety related parameters

MTTF _d	260 a
Mission Time (T _M)	20 a
Diagnostic Coverage (DC)	0 %

Indicators/operating means

Data flow display	LED green: emitter LED yellow: receiver
Function display	alignment aid: flashing front red LED Signal strength (8 LED: Red, yellow, green)

Electrical specifications

Operating voltage	U _B	18 ... 30 V DC
No-load supply current	I ₀	200 mA
Data rate		0 ... 2 MBit/s
Operation frequency		F2 = 12.5 MHz

Interface

Interface type	RS 422 , galvanically isolated
----------------	--------------------------------

Output

Pre-fault indication output	1 PNP (switches if there is sufficient stability control) short-circuit protected, max. 200 mA
-----------------------------	--

Standard conformity

Standards	EN 60947-5-2 , CE , EN 61000-6-2
-----------	----------------------------------

Ambient conditions

Ambient temperature	-10 ... 50 °C (14 ... 122 °F)
Storage temperature	-20 ... 70 °C (-4 ... 158 °F)

Mechanical specifications

Protection degree	IP65
Connection	4-pin, M12x1 connector, standard (supply) , 5-pin, M12x1 connector, B-coded (Remote Bus In) , 5-pin, M12x1 socket, B-coded (Remote Bus Out)
Material	
Housing	ABS / PC
Optical face	plastic
Mass	700 g

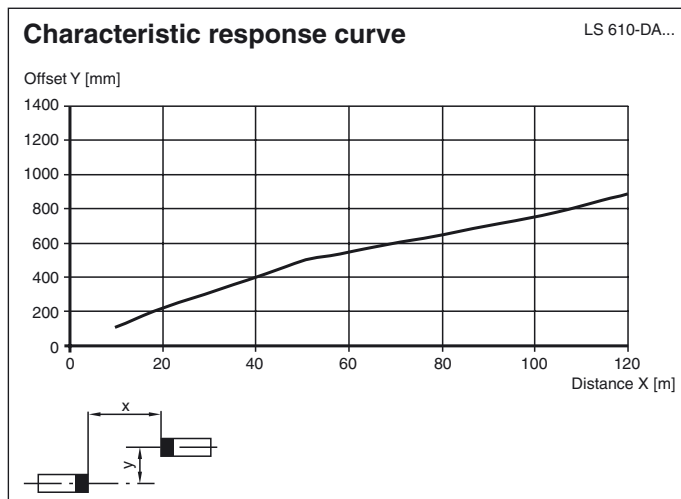
Curves/Diagrams**Function**

The LS610-DA-IBS is a device for serial data transmission in INTERBUS systems with transmission rates of up to 2 MBit/sec and ranges up to 240 m. For data rates and operating ranges lower than these values, the device can also be used with no problems.

Accessories**V15SB-G**

Cable connector, M12, for PROFIBUS, adjustable

V15B-G

Cable socket, M12, for PROFIBUS, adjustable

V15-G-PG9

Female connector, M12, 5-pin, field attachable

Funktionserdung LS610/VDM100 Zubehör

Function grounding for LS610 / LS611 / VDM100 series

Schutzkappe LS610 Zubehoer

M12 protective cap set (connector + socket) for series LS610 / LS611

OMH-LS610-01

Mounting bracket for optical data coupler

OMH-LS610-02

Direct mounting set consisting of 4 x M4 threaded inserts

OMH-LS610-03

Mounting bracket with deviation mirror for optical data coupler

OMH-LS610-05

Mounting bracket for optical data coupler and distance measurement devices

OMH-LS610-31

Mounting bracket for optical data coupler and distance measurement devices

OMH-LS610-32

Mounting bracket for optical data coupler and distance measurement devices

For one data transmission connection, an LS 610-DA-IBS unit with a mean frequency of F1 **and** an LS 610-DA-IBS unit with mean frequency F2 are required.

The LS610-DA-IBS is intended for the direct connection of Interbus S units ("extension of bus cables"). It contains no bus connection logic, and is thus not suited for spur line installations. For this reason, only one of the M12 connectors should be used at a time.

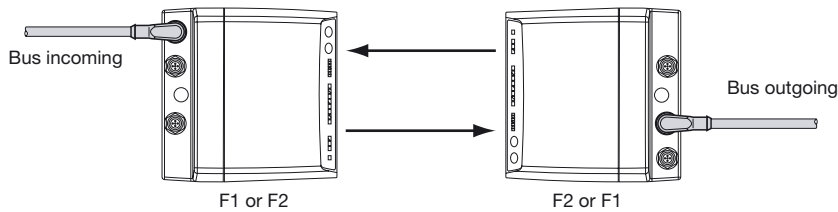

Data transmission

Data is transmitted in both directions using modulated infrared light. The information carried on the incoming bus is modulated on the carrier signal in real time using frequency shift keying (FSK). In the receiver, the corresponding demodulation is performed and the data is output on the outgoing bus. The complete transmission process is performed using no protocols. The LS610 DA-IBS includes level-type regeneration as well as complete voltage isolation of the data transmission circuits from the power supply.

Function displays/function reserves

For alignment, there is an alignment LED on the unit's face which is visible from a distance. As soon as a receiver detects the transmission light of the opposite unit, the blink frequency of the alignment aid is lowered. When it is extinguished, this signals that the units are optimally aligned with one another, and enough functional reserve is available. For fine adjustment, the data system is equipped with a bar graph display (signal display) which enables optimal alignment.

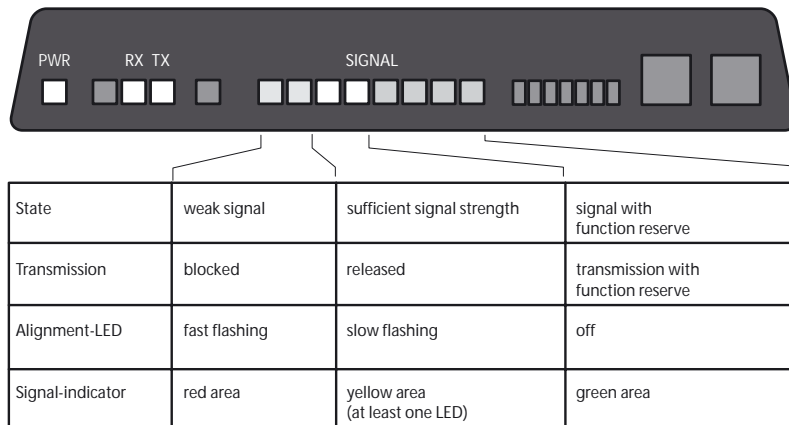

Connection between display and operational status

If the bus is active, a yellow LED "RX" is lit for received data and a green LED "TX" for transmitted data.

Installation

Installation is done with the corresponding accessories, for instance, OMH-LS610-01 for wall mounting.

The x/y adjustment is premounted at the factory. It is fastened to the mounting bracket in the desired transmission direction ($\pm 90^\circ$ rotation possible) with the two M4 screws and a central M6 screw. The middle screw is for fastening after adjustment and should only be tightened afterwards.

The data photo sensor is inserted into the notches of the adjustment device while holding both of the front bolts together with holding tabs. After insertion, the bolts are released and hold the unit securely by springing back.

Using the two adjustment screws (Inbus 5mm), the transmission axis can now be directed in the X and Y directions, and the adjustment fixed in place by tightening the middle screw.